

Errata for *Art of LEGO Mindstorms EV3* (updated to 7th printing)

Page 4: The link to the source code for the book's should now read:

<http://www.nostarch.com/artofev3programming/>

Page 17: Step 6 should now show this image:

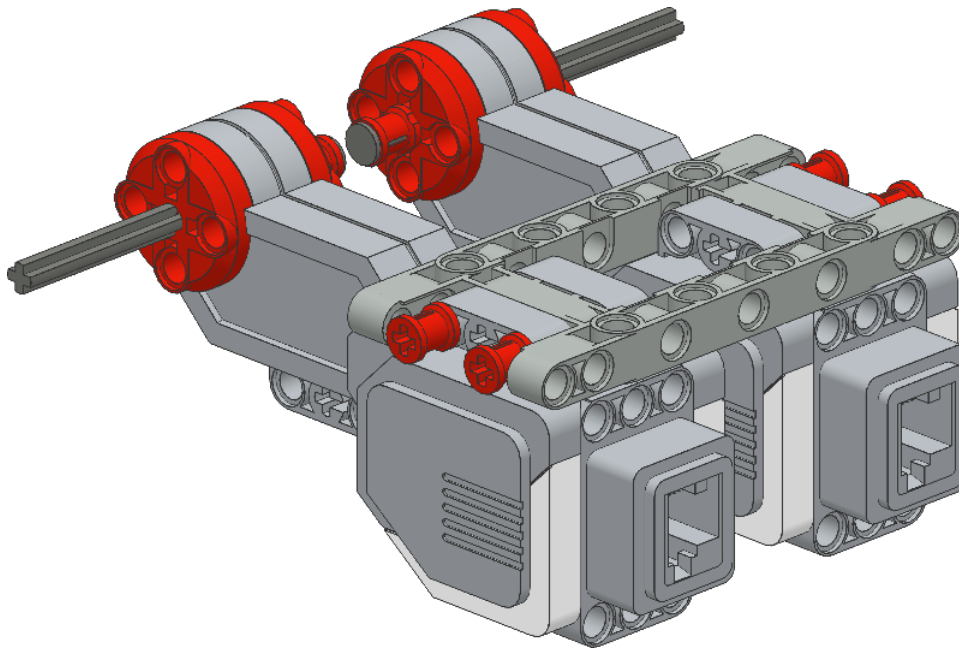

Page 133: In Figure 11-30, “Motor Rotation – Compare **Rotations**” should now read “Motor Rotation – Compare **Degrees**.”

Page 60: “**RedAndBlue**” should now read “**IsItBlue**.”

Page 75: “**RedOrBlue**” should now read “**IsItBlue**.”

Page 83: Figure 7-5 and Figure 7-6 should now be swapped.

Page 131: In Listing 11-2, both instances of “**B** motor” should now read “**C** motor.”

Pages 134-135: The “Challenge 11-1” box content should now appear right before “Further Exploration” on page 134.

Page 194: “*FileAccessTest*” should now read “*FileTestData*.”

Page 197: “*FileRead*” should now read “*FileReader*.”

Page 210: “After about 10 seconds” should now read “After about 10 **more** seconds.”

Page 213: In Table 17-3’s title, “**currentpowertest2**” should now read “**CurrentPowerTest2**.”

Page 223: In Step 5, “the **right** side of” should now read “the **left** side of.”

Page 230: “2 inches (**10** cm) away” should now read “2 inches (**5** cm) away.”

Page 231: Figure 19-5 has been updated as follows:

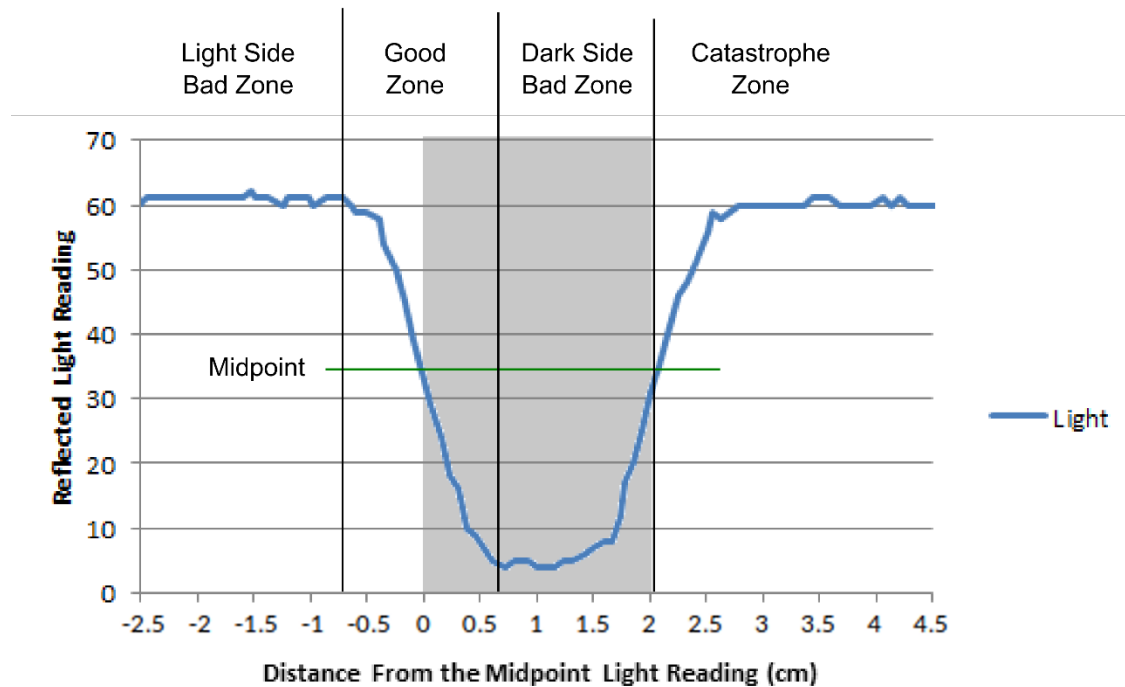

Page 232: “about 7 cm” should now read “about 0.7 cm,” “more than 7 cm” should now read “more than 0.7 cm,” “10 or 20 cm” should now read “1 or 2 cm,” “between 7 and 12 cm” should now read “between 0.7 and 1.2 cm,” and “beyond 12 cm” should now read “beyond 1.2 cm.”

Page 233: “about 2 cm” should now read “about 0.2 cm.”

Page 236: We deleted the two sentences: “Note that the Error value is stored in a variable instead of being passed straight to the Math block—this will make things easier as the program gets bigger. The Direction value is applied using a separate Math block for the same reason.”